



US008803172B2

(12) **United States Patent**
Kim et al.

(10) **Patent No.:** **US 8,803,172 B2**
(45) **Date of Patent:** **Aug. 12, 2014**

(54) **TOP EMISSION INVERTED ORGANIC LIGHT EMITTING DIODE DISPLAY DEVICE HAVING ELECTRODE PATTERNS FORMED FROM A SAME MATERIAL AS A CONDUCTIVE PATTERN CONTACTING THE TFT**

(75) Inventors: **Yong Chul Kim**, Gyeonggi-do (KR);
Juhn Suk Yoo, Gyeonggi-do (KR)

(73) Assignee: **LG Display Co., Ltd.**, Seoul (KR)

(*) Notice: Subject to any disclaimer, the term of this patent is extended or adjusted under 35 U.S.C. 154(b) by 233 days.

(21) Appl. No.: **12/639,414**

(22) Filed: **Dec. 16, 2009**

(65) **Prior Publication Data**

US 2010/0213482 A1 Aug. 26, 2010

(30) **Foreign Application Priority Data**

Feb. 24, 2009 (KR) 10-2009-0015460

(51) **Int. Cl.**
H01L 27/32 (2006.01)
H01L 51/52 (2006.01)

(52) **U.S. Cl.**
CPC **H01L 27/3246** (2013.01); **H01L 27/3248** (2013.01); **H01L 27/3258** (2013.01); **H01L 27/3276** (2013.01); **H01L 51/5221** (2013.01); **H01L 2227/323** (2013.01); **H01L 2251/5315** (2013.01)
USPC **257/98**; 257/72; 349/41

(58) **Field of Classification Search**
CPC H01L 27/3246; H01L 27/3248; H01L 27/3258; H01L 27/3276; H01L 51/2221; H01L 2227/323; H01L 2251/5315
USPC 257/72, 98, E51.019
See application file for complete search history.

(56) **References Cited**

U.S. PATENT DOCUMENTS

6,620,655 B2 * 9/2003 Ha et al. 438/149
6,888,597 B2 * 5/2005 Ha et al. 349/114

(Continued)

FOREIGN PATENT DOCUMENTS

CN 1992264 A 7/2007
JP 2005-196172 A 7/2005

(Continued)

OTHER PUBLICATIONS

Chinese Office Action dated Mar. 30, 2011 for Chinese Application No. CN 200910226073.1.

(Continued)

Primary Examiner — Anh Mai

(74) *Attorney, Agent, or Firm* — Morgan, Lewis & Bockius LLP

(57) **ABSTRACT**

A top emission inverted OLED device is disclosed. The a top emission inverted OLED device includes: first and second pad portions disposed on peripheral areas which correspond to outer sides of a light generation area on a metal substrate; at least one thin film transistor formed on the light generation area; a passivation layer formed to cover the thin film transistor on the metal substrate and include contact holes which partially expose the thin film transistor and the first and second pad portions; a stacked pattern of first and second conductive patterns formed on the passivation layer and configured to make contact with the exposed part of the thin film transistor through one of the contact holes; a cathode electrode formed on the light generation area and electrically connected to the second conductive pattern; an organic light emission layer disposed on the cathode electrode; an anode electrode disposed on the organic light emission layer and formed from a transparent metal material; and electrode patterns formed from the same material as the second conductive pattern on the rest of the contact holes which expose the first and second pad portions.

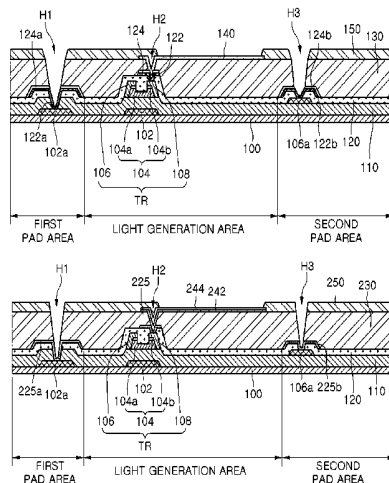

8 Claims, 13 Drawing Sheets

(56)

References Cited

U.S. PATENT DOCUMENTS

7,022,557	B2 *	4/2006	Kim et al.	438/149
7,109,655	B2 *	9/2006	Kurihara	313/512
8,227,803	B2 *	7/2012	Park	257/40
2005/0140877	A1	6/2005	Jeoung et al.	
2007/0152222	A1	7/2007	Joo	257/72
2008/0231168	A1	9/2008	Choi	
2009/0021454	A1	1/2009	Satou et al.	

FOREIGN PATENT DOCUMENTS

JP	2009-027037	A	2/2009
KR	10-2008-0086201	A	9/2008

OTHER PUBLICATIONS

KIPO—Office Action for Korean Patent Application No. 10-2009-0015460—Issued on Jan. 28, 2013.

* cited by examiner

FIG. 1

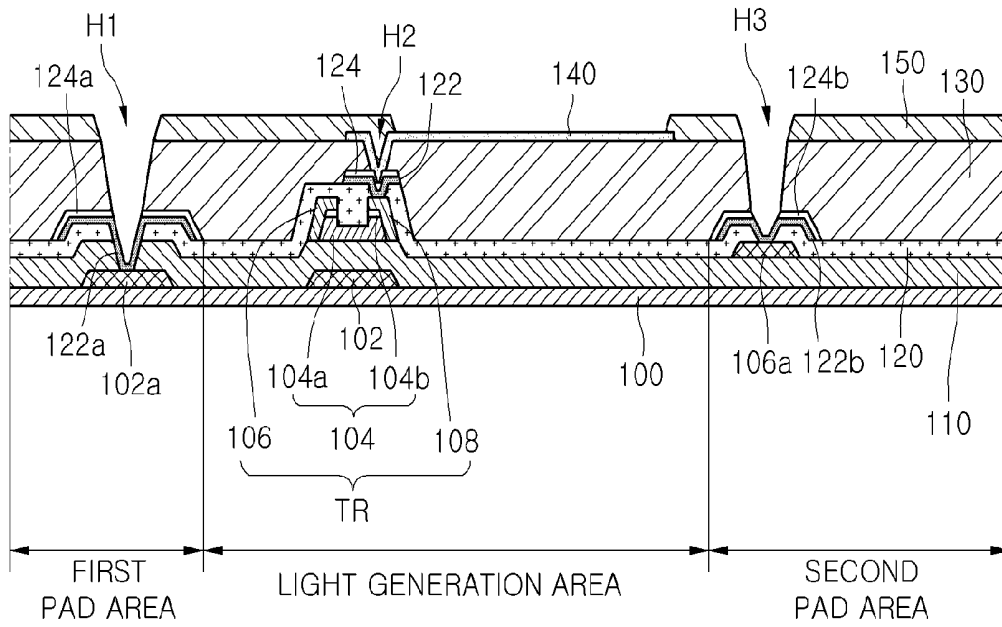

FIG. 2A

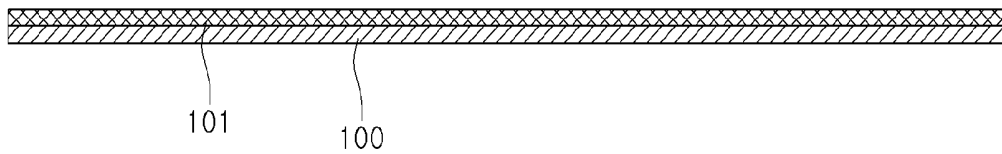

FIG. 2B

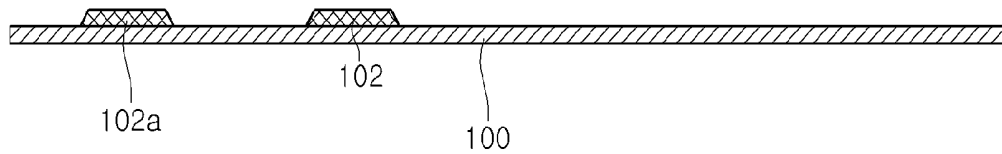

FIG. 2C

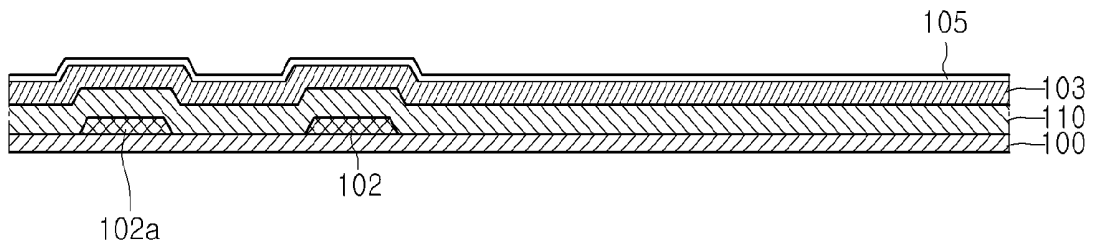

FIG. 2D

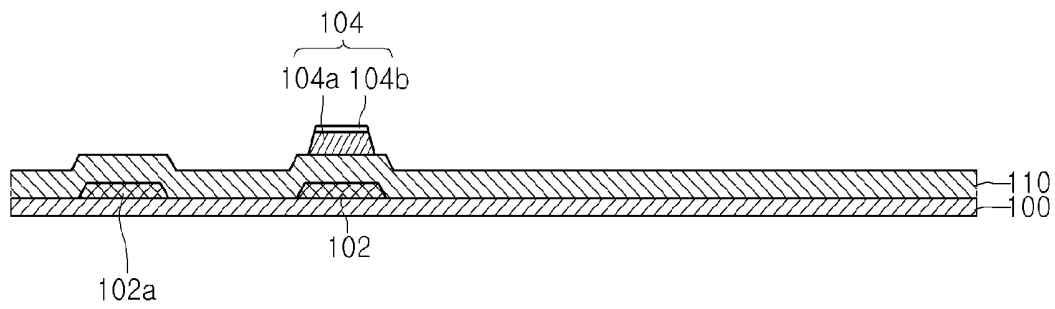

FIG. 2E

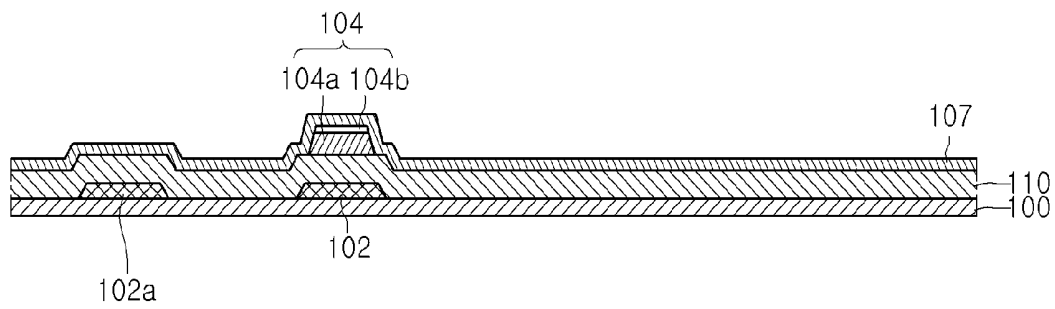

FIG. 2F

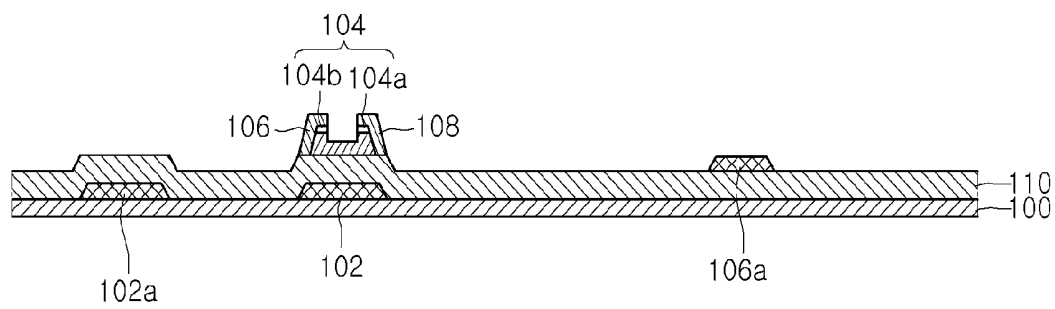

FIG. 2G

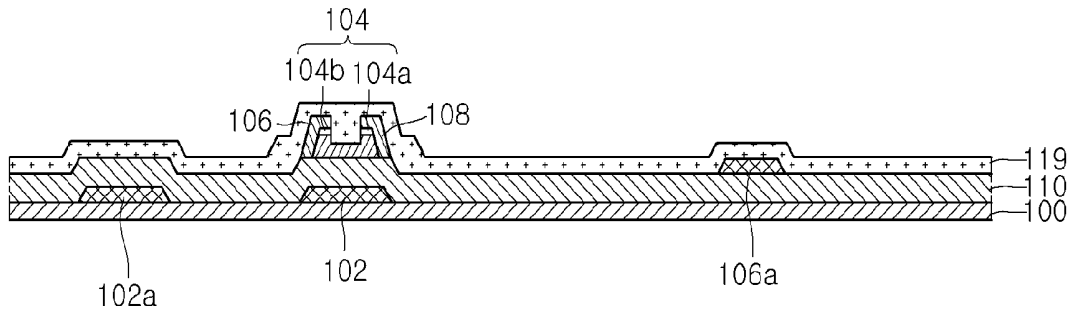

FIG. 2H

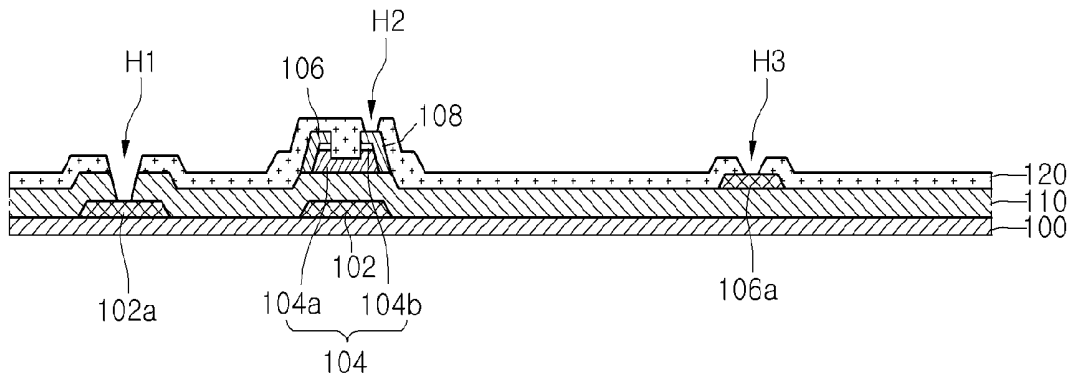

FIG. 2I

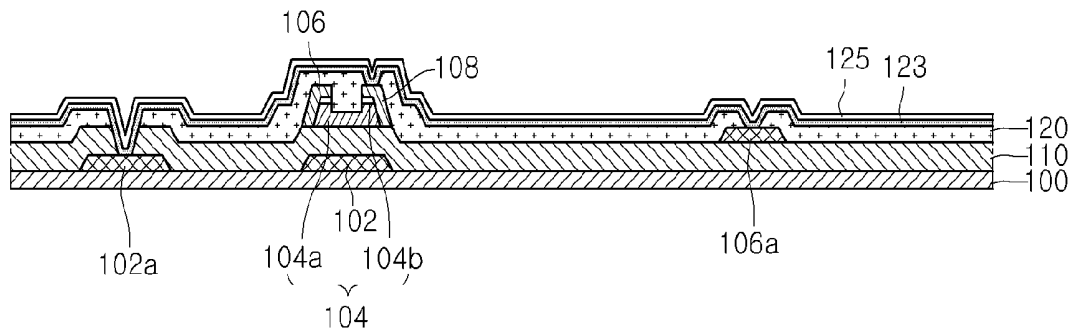

FIG. 2J

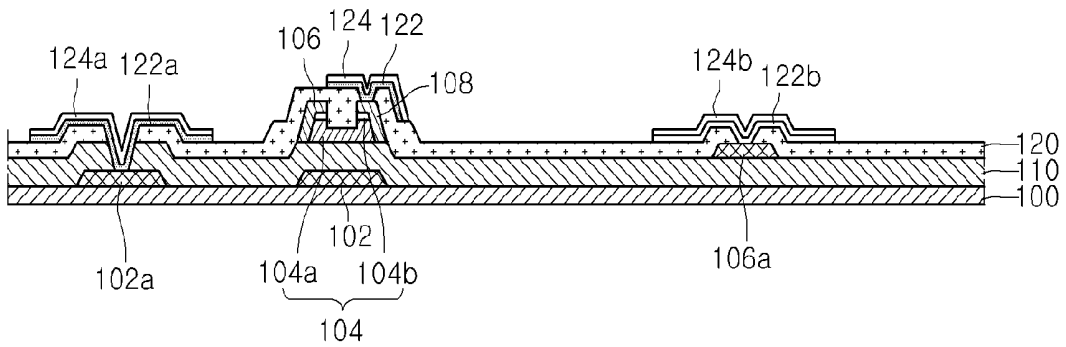

FIG. 2K

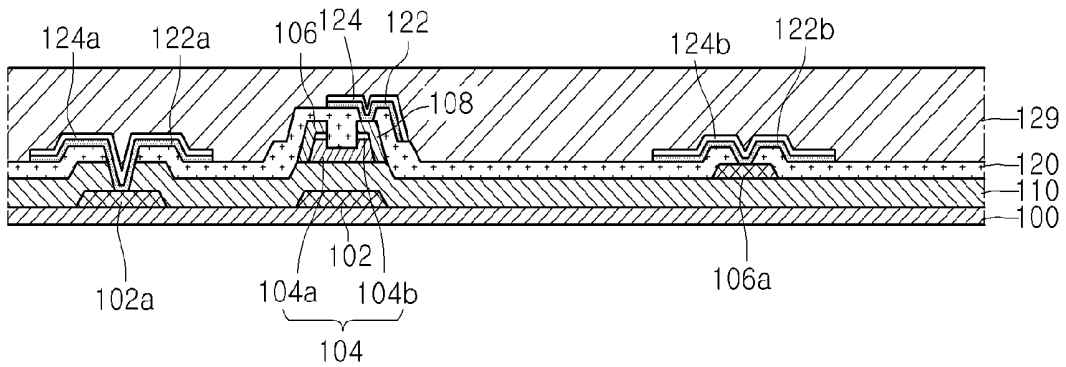

FIG. 2L

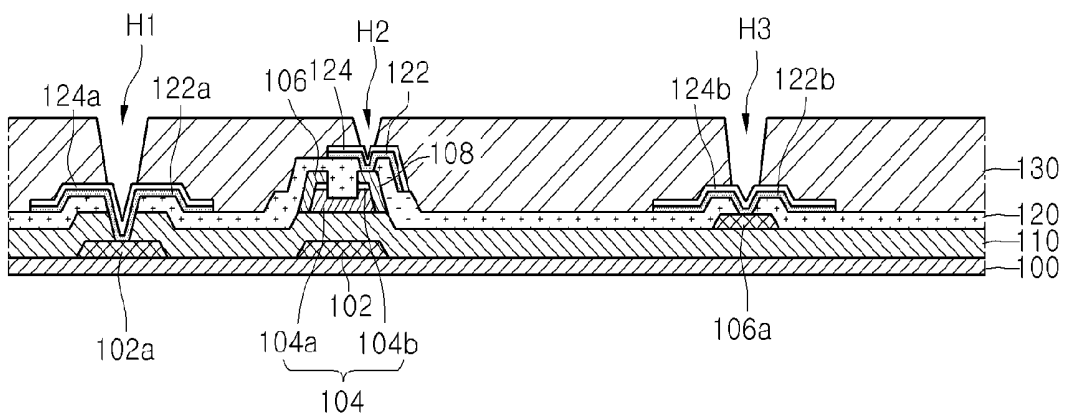

FIG. 2M

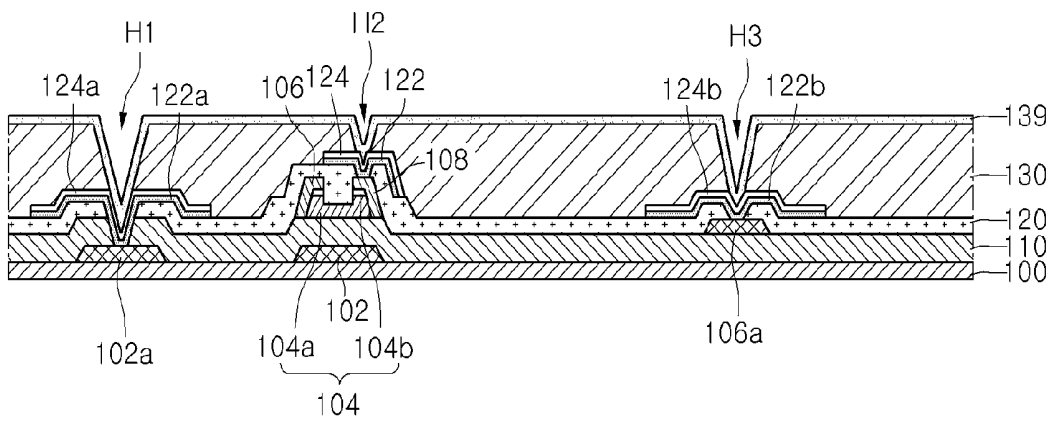

FIG. 2N

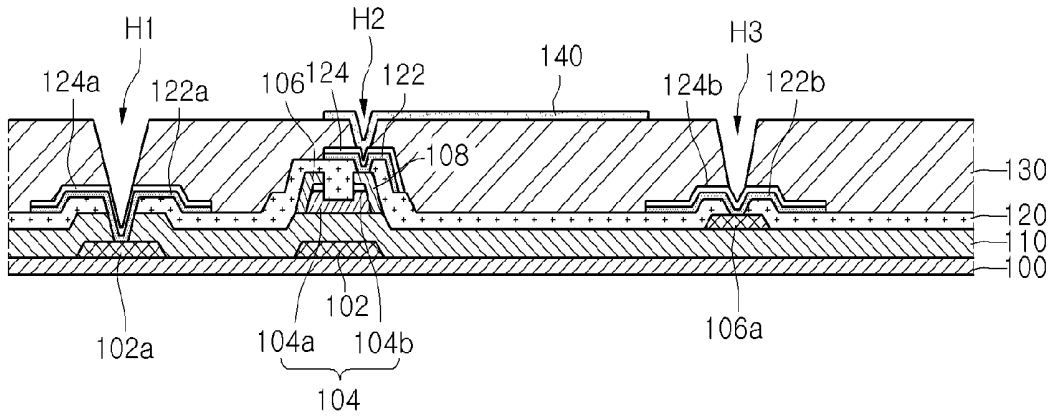

FIG. 2O

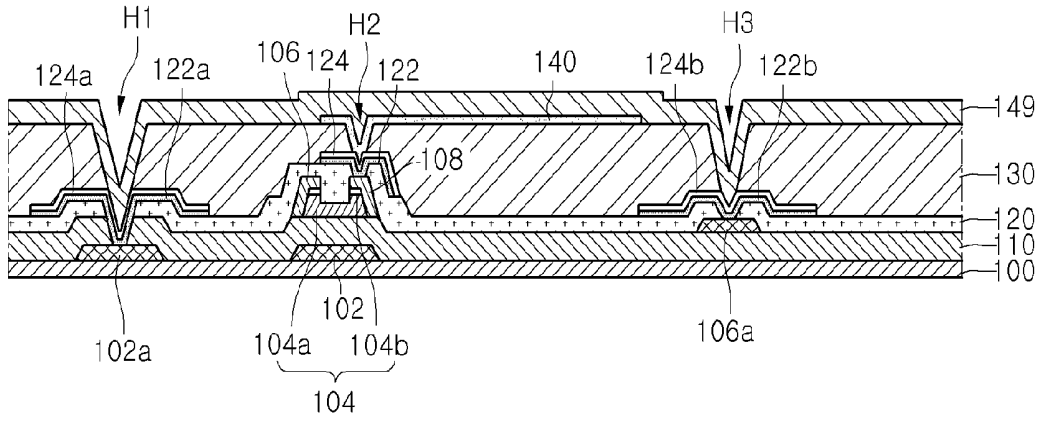

FIG. 2P

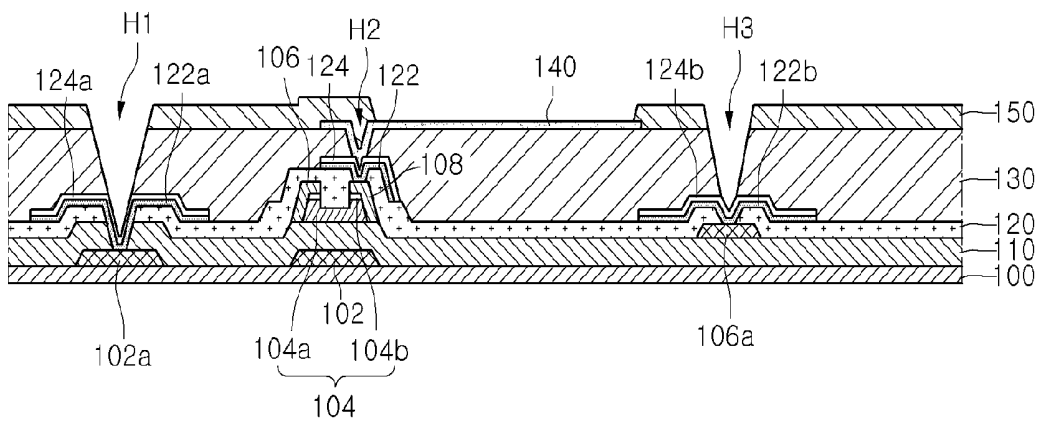

FIG. 2Q

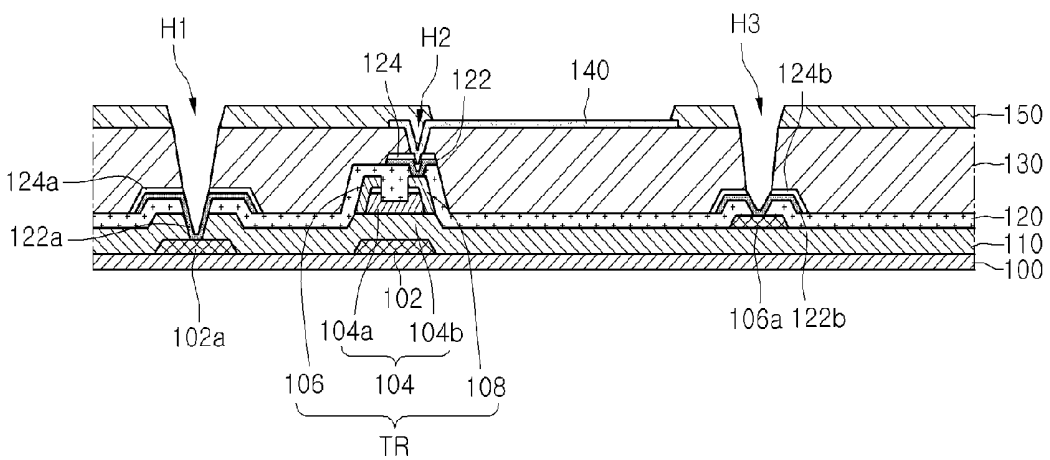

FIG. 3

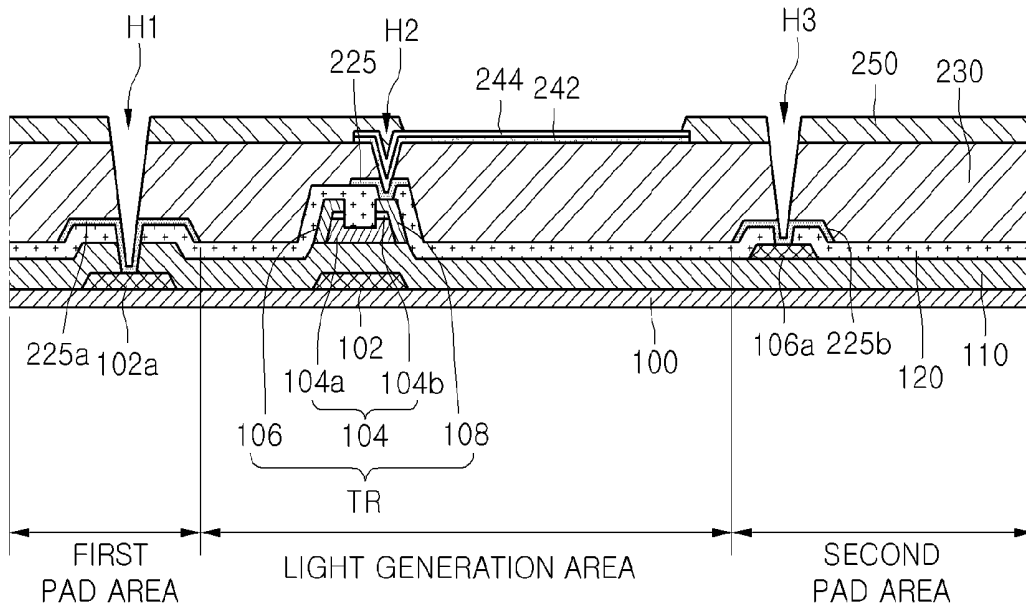

FIG. 4A

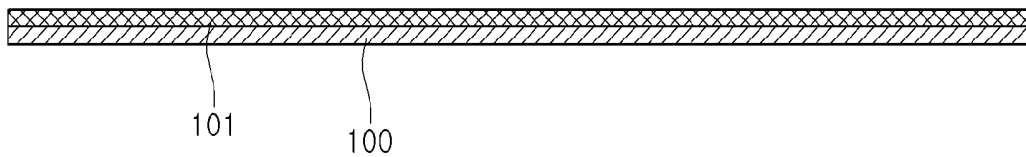

FIG. 4B

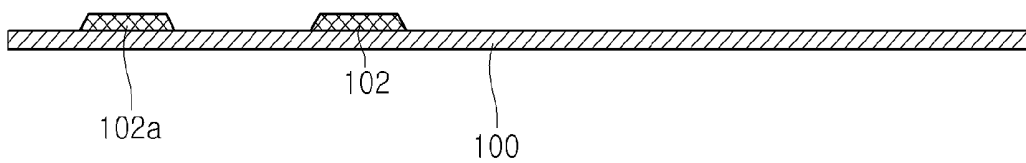

FIG. 4C

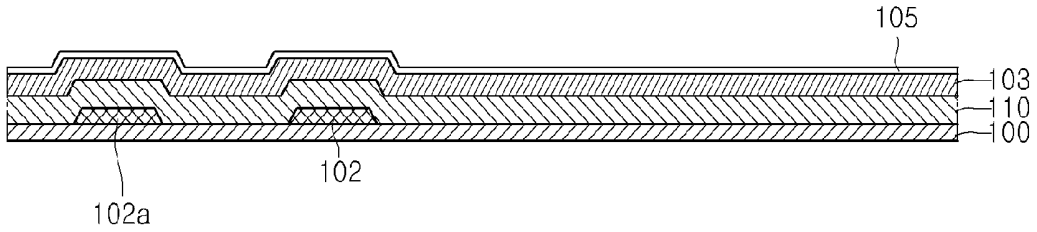

FIG. 4D

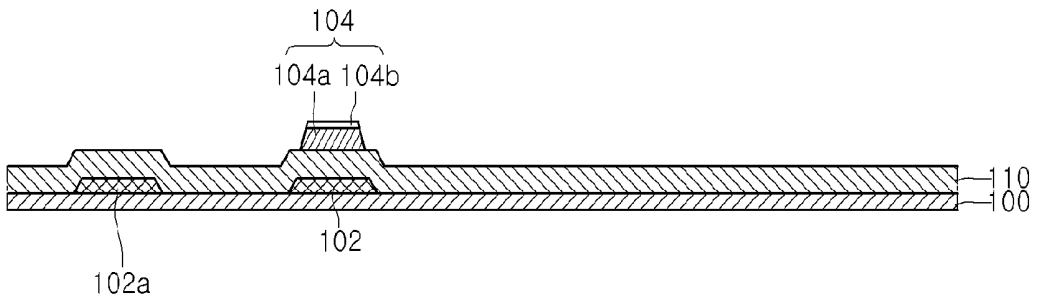

FIG. 4E

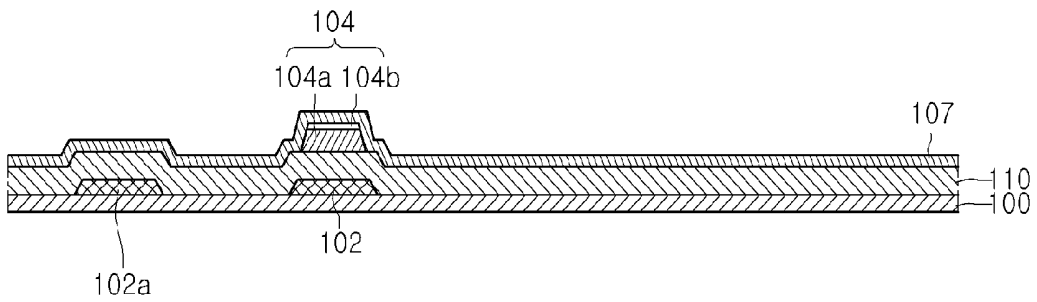

FIG. 4F

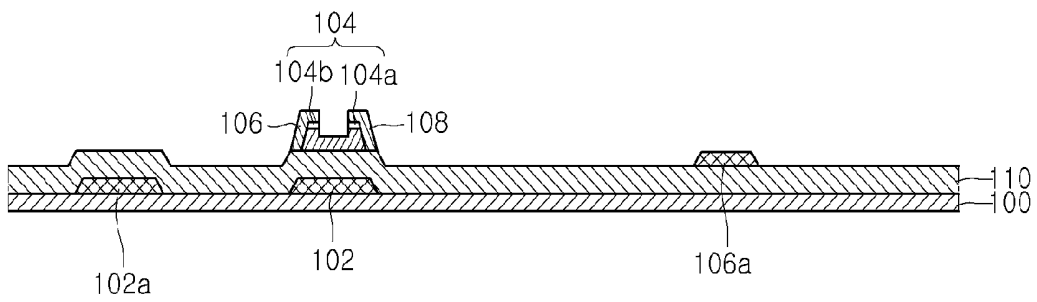

FIG. 4G

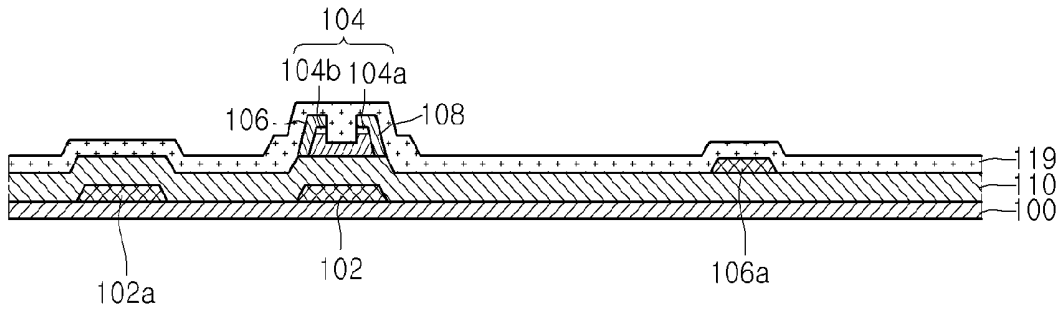

FIG. 4H

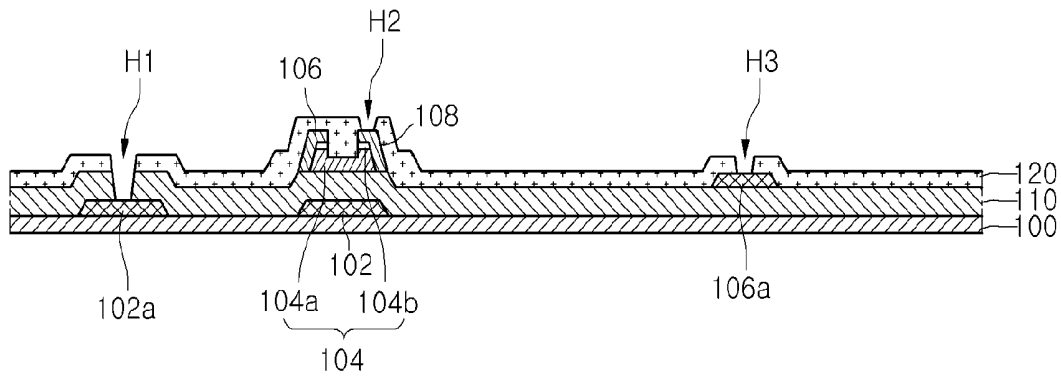

FIG. 4I

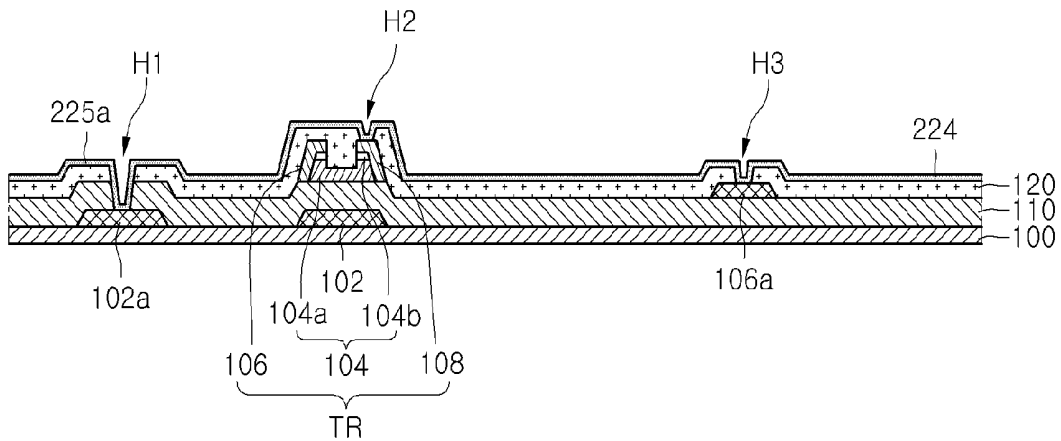

FIG. 4J

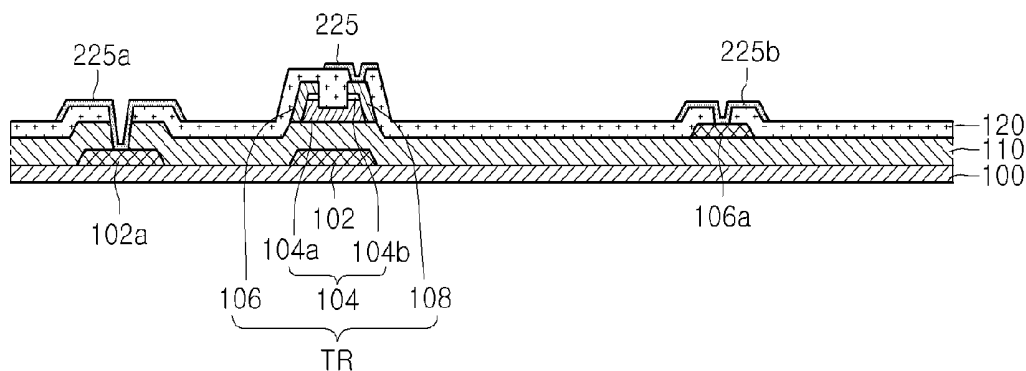

FIG. 4K

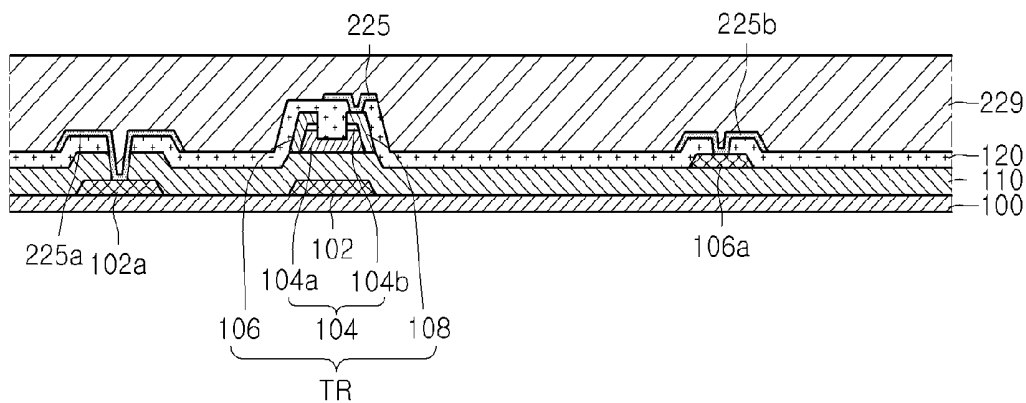

FIG. 4L

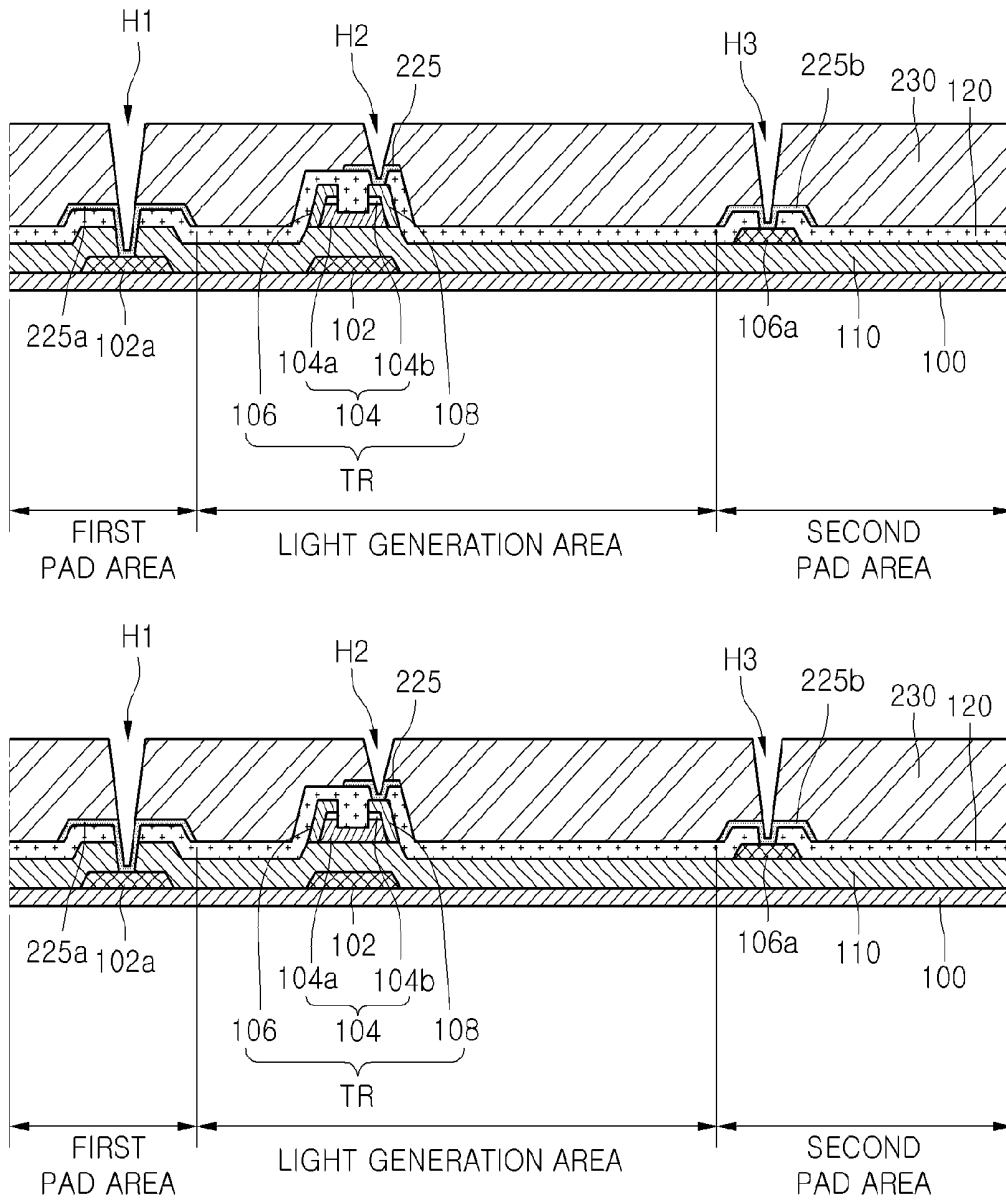

FIG. 4M

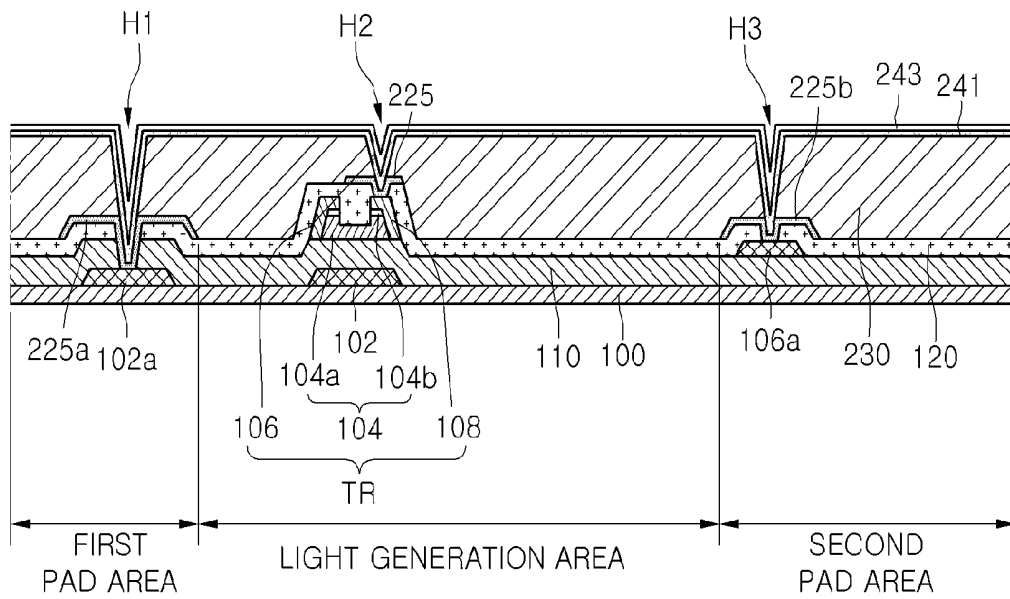

FIG. 4N

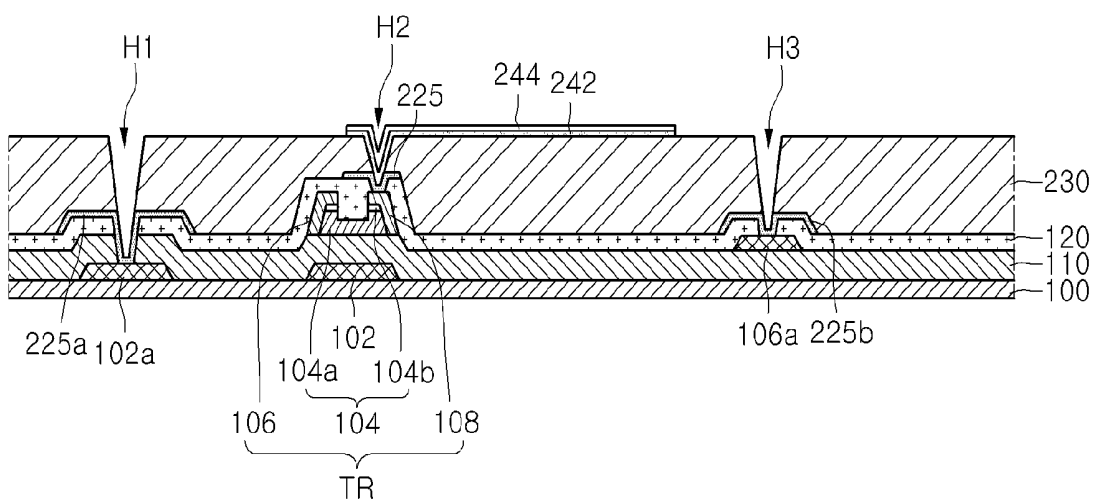

FIG. 4O

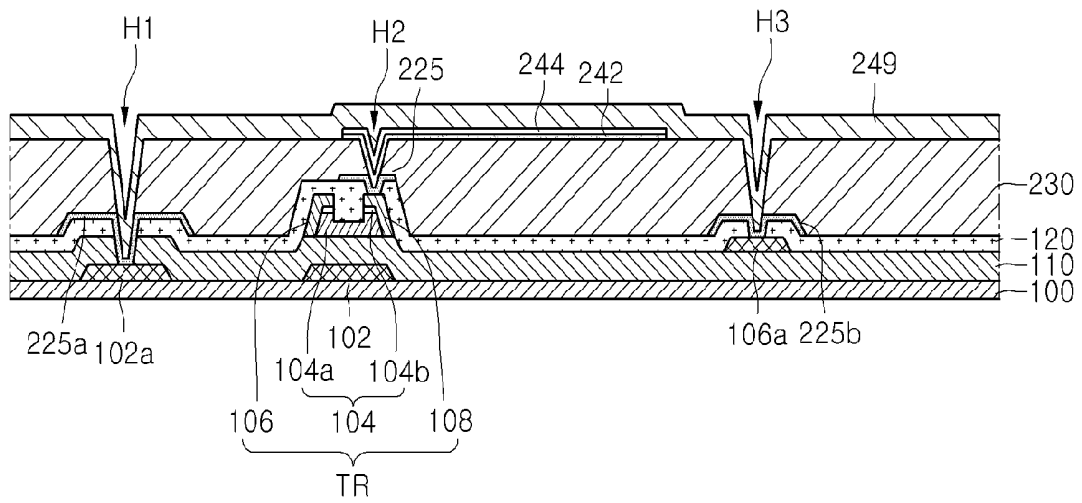
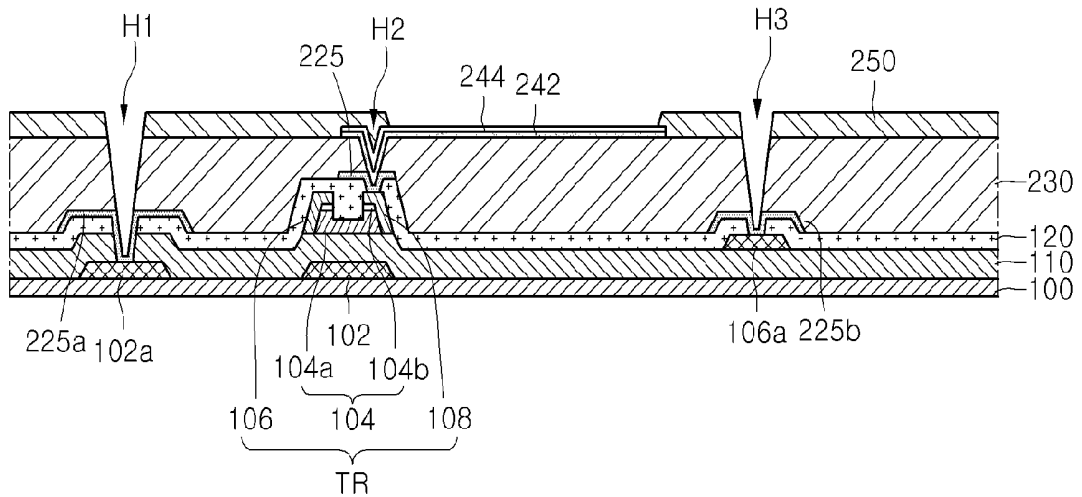

FIG. 4P



**TOP EMISSION INVERTED ORGANIC
LIGHT EMITTING DIODE DISPLAY DEVICE
HAVING ELECTRODE PATTERNS FORMED
FROM A SAME MATERIAL AS A
CONDUCTIVE PATTERN CONTACTING THE
TFT**

CROSS-REFERENCE TO RELATED
APPLICATION

This application claims priority under 35 U.S.C. 119 to Korean Patent Application No 10-2009-0015460, filed on Feb. 24, 2009, which is hereby incorporated by reference in its entirety.

BACKGROUND

1. Field of the Disclosure

This disclosure relates to an organic light emitting diode display (OLED) device, and more particularly to an OLED device of the top-emission inverted type adapted to reduce the process of forming a thin film transistor on a metal substrate, and a manufacturing method thereof.

2. Description of the Related Art

OLED devices of a self luminous type can be light and slim since they do not need the backlight units required for liquid crystal display devices. Also, the OLED devices can be manufactured through a simple process. Moreover, the OLED devices have a low voltage drive, a high luminous efficiency, and a wide viewing angle. In view of these points, the OLED devices have received a growing amount of attention as one of next-generation display devices.

The OLED devices each include thin film transistors arranged on a substrate, organic light emitting diodes connected to the respective thin film transistors, and a seal substrate covering the organic light emitting diodes. The organic light emitting diodes are configured to emit light. Such OLED devices can be classified into a bottom emission type and a top emission type according to light emitting directions.

The top emission OLED device is configured to emit light through a seal substrate. As such, the top emission OLED device has a larger aperture ratio than that of the bottom emission OLED device. Moreover, the top emission OLED device can be designed in a variety of formations because the aperture ratio is not subject to a driving element.

However, the top emission OLED device employs a process of forming a thin film transistor using a maximum of 11 masks. In other words, the formation process of a thin film transistor is very complex. As such, the manufacturing efficiency of the top emission OLED device is deteriorated and manufacturing costs of the top emission OLED device increases.

Moreover, the top emission OLED device includes cathode electrodes formed by patterning a corrodible conductive material in pixels, and an organic light emission layer and anodes sequentially formed on the cathode electrodes. As such, the cathode electrodes are very easily corroded. Such corrosion of the cathode electrodes deteriorates the reliability of the top emission OLED device.

BRIEF SUMMARY

Accordingly, the present embodiments are directed to a top emission inverted OLED device that substantially obviates one or more of problems due to the limitations and disadvantages of the related art, and a manufacturing method thereof.

An object of the present embodiments is to provide a top emission inverted OLED device with enhanced reliability and a manufacturing method thereof.

Another object of the present embodiments is to provide a top emission OLED device that is adapted to simplify a manufacturing process, and a manufacturing method thereof.

Additional features and advantages of the embodiments will be set forth in the description which follows, and in part will be apparent from the description, or may be learned by practice of the embodiments. The advantages of the embodiments will be realized and attained by the structure particularly pointed out in the written description and claims hereof as well as the appended drawings.

According to one general aspect of the present embodiment, a top emission inverted OLED device includes: first and second pad portions disposed on peripheral areas which correspond to outer sides of a light generation area on a metal substrate; at least one thin film transistor formed on the light generation area; a passivation layer formed to cover the thin film transistor on the metal substrate and include contact holes which partially expose the thin film transistor and the first and second pad portions; a stacked pattern of first and second conductive patterns formed on the passivation layer and configured to make contact with the exposed part of the thin film transistor through one of the contact holes; a cathode electrode formed on the light generation area and electrically connected to the second conductive pattern; an organic light emission layer disposed on the cathode electrode; an anode electrode disposed on the organic light emission layer and formed from a transparent metal material; and electrode patterns formed from the same material as the second conductive pattern on the rest of the contact holes which expose the first and second pad portions.

A top emission inverted OLED device according to another aspect of the present embodiment includes: first and second pad portions disposed on peripheral areas which correspond to outer sides of a light generation area on a metal substrate; at least one thin film transistor formed on the light generation area; a passivation layer formed to cover the thin film transistor on the metal substrate and include contact holes which partially expose the thin film transistor and the first and second pad portions; a conductive pattern formed on the passivation layer and configured to make contact with the exposed part of the thin film transistor through one of the contact holes; a first cathode electrode formed on the light generation area and electrically connected to the conductive pattern; a second cathode electrode formed on the first cathode electrode; an organic light emission layer disposed on the second cathode electrode; an anode electrode disposed on the organic light emission layer and formed from a transparent metal material; and electrode patterns formed from the same material as the conductive pattern on the rest of the contact holes which expose the first and second pad portions.

A method of manufacturing a top emission inverted OLED device, according to still another aspect of the present embodiment, includes: preparing a metal substrate defined into a light generation area and first and second pad areas positioned adjacent thereto; forming at least one thin film transistor on the light generation area; forming a passivation layer which is configured to cover the thin film transistor on the metal substrate and include contact holes partially exposing the thin film transistor and the first and second pad areas; forming first and second conductive patterns, which are configured to make contact with the exposed part of the thin film transistor through one of the contact holes, by sequentially depositing and patterning first and second conductive layers on the passivation layer; forming a planarization layer, which

is configured to partially expose the thin film transistor and the first and second pad areas, on the metal substrate with the first and second conductive patterns; forming a cathode electrode, which is electrically connected to the second conductive pattern, on the metal substrate covered with the planarization layer; forming a bank pattern, which is configured to partially expose the cathode electrode and the first and second pad areas, on the metal substrate with the cathode electrode; forming an organic light emission layer on the exposed cathode electrode; and forming an anode electrode of a transparent conductive material on the organic light emission layer, wherein electrode patterns are formed, from the same material as the second conductive pattern, on the rest of the contact holes which expose the first and second pad areas.

A method of manufacturing a top emission inverted OLED device, according to further still another aspect of the present embodiment, includes: preparing a metal substrate defined into a light generation area and first and second pad areas positioned adjacent thereto; forming at least one thin film transistor on the light generation area; forming a passivation layer which is configured to cover the thin film transistor on the metal substrate and include contact holes partially exposing the thin film transistor and the first and second pad areas; forming a conductive pattern, which is configured to make contact with the exposed part of the thin film transistor through one of the contact holes, by depositing and patterning a conductive layer on the passivation layer; forming a planarization layer, which is configured to partially expose the thin film transistor and the first and second pad areas, on the metal substrate with the conductive pattern; forming first and second cathode electrodes, which is electrically connected to the conductive pattern, by sequentially stacking and patterning first and second metal layers on the metal substrate covered with the planarization layer; forming a bank pattern, which is configured to partially expose the second cathode electrode and the first and second pad areas, by providing and patterning a bank layer on the metal substrate with the first and second cathode electrodes; forming an organic light emission layer on the exposed second cathode electrode; and forming an anode electrode of a transparent metal material on the organic light emission layer, wherein electrode patterns are formed, from the same material as the conductive pattern, on the rest of the contact holes which expose the first and second pad areas.

Other systems, methods, features and advantages will be, or will become, apparent to one with skill in the art upon examination of the following figures and detailed description. It is intended that all such additional systems, methods, features and advantages be included within this description, be within the scope of the invention, and be protected by the following claims. Nothing in this section should be taken as a limitation on those claims. Further aspects and advantages are discussed below in conjunction with the embodiments. It is to be understood that both the foregoing general description and the following detailed description of the present disclosure are exemplary and explanatory and are intended to provide further explanation of the disclosure as claimed.

BRIEF DESCRIPTION OF THE DRAWINGS

The accompanying drawings, which are included to provide a further understanding of the embodiments and are incorporated in and constitute a part of this application, illustrate embodiment(s) of the invention and together with the description serve to explain the disclosure. In the drawings:

FIG. 1 is a cross-sectional view showing schematically a top emission inverted OLED device according to a first embodiment of the present disclosure;

FIG. 2A to 2Q are cross-sectional views sequentially illustrating a process of manufacturing a top emission inverted OLED device of FIG. 1;

FIG. 3 is a cross-sectional view showing schematically a top emission inverted OLED device according to a second embodiment of the present disclosure; and

FIG. 4A to 4P are cross-sectional views sequentially illustrating a process of manufacturing a top emission inverted OLED device of FIG. 3.

DETAILED DESCRIPTION

Reference will now be made in detail to the embodiments of the present disclosure, examples of which are illustrated in the accompanying drawings. These embodiments introduced hereinafter are provided as examples in order to convey their spirits to the ordinary skilled person in the art. Therefore, these embodiments might be embodied in a different shape, so are not limited to these embodiments described here. Also, the size and thickness of the device might be expressed to be exaggerated for the sake of convenience in the drawings. Wherever possible, the same reference numbers will be used throughout this disclosure including the drawings to refer to the same or like parts.

Referring to FIG. 1, the top emission inverted OLED device according to a first embodiment of the present disclosure includes a substrate **100** defined into a light generation area and peripheral areas thereof. The substrate **100** includes first and second pad portions each disposed on the peripheral areas. The substrate **100** is formed from a metal material. The first pad portion can include a gate pad portion, and the second pad portion can include a data pad portion.

At least one thin film transistor TR is formed on the light generation area of the substrate **100**. The thin film transistor TR can be configured to include a gate electrode **102** covered with a gate insulation film **110**, a semiconductor pattern **104** disposed opposite the gate electrode **102** in the center of the gate insulation film **110**, and a source electrode **106** and a drain electrode **108** arranged separately in a fixed interval from each other on the semiconductor pattern **104**. The semiconductor pattern **104** can include an active layer **104a** formed from an amorphous silicon pattern, and ohmic contact layers **104b** each formed from an impurity-doped amorphous silicon pattern. The ohmic contact layers **104b** are interposed between the active layer **104a** and the source electrode **106** as well as between the active layer **104a** and the drain electrode **108**, respectively.

The top emission inverted OLED device further can include a passivation (or a protective) layer **120** covering the thin film transistor TR on the substrate **100**. The passivation layer **120** can be formed from an inorganic insulation material such as a silicon oxide material or a silicon nitride material. A first conductive pattern **122** and a second conductive pattern **124** are sequentially formed on the passivation layer **120** opposite to the thin film transistor **120**. A second contact hole H2 is formed on the passivation layer **120** partially exposing the drain electrode **108**. As such, the first conductive pattern **122** is electrically connected to the drain electrode **108** through the second contact hole H2.

The gate pad portion includes a lower gate pad electrode **102a** formed from the same metal material as the gate electrode **102**, and a stacked conductive pattern of first and second upper gate pad electrodes **122a** and **124a** formed on the passivation layer **120**. The lower gate pad electrode **102a** is

covered with the gate insulation **110**, and the passivation layer **120** is formed on the gate insulation film **110**. As such, the lower gate pad electrode **102a** is opposite the stacked conductive pattern of first and second upper gate pad electrodes **122a** and **124a** in the center of the gate insulation film **110** and the passivation layer **120**. The lower gate pad electrode **102a** is partially exposed by a second contact hole H2 penetrating through the passivation layer **120** and the gate insulation film **110**. The first upper gate pad electrode **122a** is electrically connected to the lower gate pad electrode **102a** via the first contact hole H1.

The data pad portion includes a lower data pad electrode **106a** formed from the same metal material as the source and drain electrodes **106** and **108** of the thin film transistor TR, and a stacked conductive pattern of first and second upper data pad electrodes **122b** and **124b** formed on the passivation layer **120** and opposite to the lower data pad electrode **106b**. The lower data pad electrode **106a** is disposed on the gate insulation film **110** coated on the substrate **100**. Also, the lower data pad electrode is partially exposed by a third contact hole H3 penetrating through the passivation layer **120**. The first upper data pad electrode **122b** is electrically connected to the lower data pad electrode **106a** via the third contact hole H3. The first upper data pad electrode **122b** together with the first upper gate pad electrode **122a** can be formed from the same material as the first conductive pattern **122**. Similarly, the second upper data pad electrode **124b** together with the second upper gate pad electrode **124a** can be formed from the second conductive pattern **124**.

The top emission inverted OLED device further includes a planarization layer **130** formed on the entire surface of the substrate **100** which is provided with the thin film transistor TR and the gate and data pad portions. The planarization layer **130** can be formed from an organic material such as polyimide, polyacryl or others. The planarization layer is flat and eliminates step coverages which are caused by the thin film transistor TR and the gate and data pad portions.

Moreover, the top emission inverted OLED device includes a cathode electrode **140** formed on the substrate covered with the planarization layer **130**, and a bank pattern **150** on the substrate **100** provided with the cathode electrode **140**. The cathode electrode **140** is electrically connected to the second conductive pattern **124** on the light generation area of the substrate **100** through the planarization layer **130**. The bank pattern **150** is formed to partially expose the cathode electrode **140**. Such a bank pattern **150** is formed to rim the cathode electrode **140**, by depositing a sensitive insulation material such as polyimide or others and patterning the sensitive insulation material through a photography process. Normally, the bank pattern **150** is formed between the cathode electrodes **140** as the top emission inverted OLED device includes a plurality of light emitting diodes.

FIG. 2A to 2Q are cross-sectional views sequentially illustrating a process of manufacturing a top emission inverted OLED device of FIG. 1.

As shown in FIG. 2A, a first metal layer **101** is formed on a metal substrate **100**. Although it is not shown in the drawings, an insulation film may be coated on the metal substrate **100** before the formation of the first metal layer **101**. The first metal layer **101** is patterned by a photolithography process using a first mask (not shown), so that a gate electrode **102** and a lower gate pad electrode **102a** are provided as shown in FIG. 2B. The gate electrode **102** is formed on a light generation area. The lower gate pad electrode **102a** is formed on a gate pad area which corresponds to any one of the peripheral areas of the light generation area.

Then, a gate insulation film **110** is formed on the entire surface of the metal substrate **100** provided with the gate electrode **102** and the lower gate pad electrode **102a**, as shown in FIG. 2C. Also, an amorphous silicon film **103** and an impurity-doped amorphous silicon film **105** are sequentially stacked on the entire surface of the metal substrate **100** covered with the gate insulation film **110**. The sequentially stacked layers of the amorphous silicon film **103** and the impurity-doped amorphous silicon film **105** are patterned by a photolithography process using a second mask (not shown), and defined into an active layer pattern **104a** and an ohmic contact layer pattern **104b** which are stacked opposed the gate electrode **102**, respectively, as shown in FIG. 2D. The active layer pattern **104a** and the ohmic contact layer pattern **104b** configure a semiconductor pattern **104**.

As shown in FIG. 2E, a second metal layer **107** is formed on the entire surface of the metal substrate provided with the semiconductor pattern **104**. The second metal layer **107** is patterned into a source electrode **106**, a drain electrode **108**, and a lower data pad electrode **106a** by a photolithography process using a third mask (not shown), as shown in FIG. 2F. The source electrode **106** and the drain electrode **108** are separated at a fixed interval from each other, and the lower data pad electrode **106b** is positioned at the data pad area which corresponds to another one of the peripheral areas of the light generation area. At the same time, the ohmic contact layer pattern **104** is partially removed to expose the active layer pattern **104** between the source and drain electrodes **106** and **108**.

Also, a passivation (or a protective) layer **119** is formed on the entire surface of the metal substrate **100** provided with the source electrode **106**, the drain electrode **108**, and the lower data pad electrode **106a**, as shown in FIG. 2G. The passivation layer **119** is patterned through a photolithography process using a fourth mask (not shown), and defined into a passivation layer **120** with first to third contact holes H1~H3, as shown in FIG. 2H. The first contact hole H1 exposes a part of the lower gate electrode **102a** by penetrating through the passivation layer **120** and the gate insulation film **110**. The second contact hole H2 partially exposes the drain electrode **108**. The third contact hole H3 exposes a part of the lower data pad electrode **106a**. To this end, the first contact hole H1 is formed on the gate pad area, the second contact hole H2 is formed on the light generation area, and the third contact hole H3 is formed on the data pad area.

Subsequently, first and second conductive layers **123** and **125** are sequentially stacked on the entire surface of the metal substrate **100** covered with the passivation layer **120**, as shown in FIG. 2I. The first conductive layer **123** can be formed to include indium-tin-oxide (ITO), and the second conductive layer **125** can be formed to include molybdenum (Mo). The second conductive layer **125** containing Mo is used in preventing a galvanic phenomenon generated between the first conductive layer **123** and a cathode electrode (**140** in FIG. 1) which will be described below. The first and second conductive layers **123** and **125** are patterned by a photolithography process using a fifth mask (not shown), so as to be defined into a pair of stacked first and second conductive patterns **122** and **124**, a pair of stacked first and second upper gate pad electrodes **122a** and **124a**, and a pair of stacked first and second upper data pad electrodes **122b** and **124b**, as shown in FIG. 2J.

More specifically, the first conductive layer **123** is patterned into the first conductive pattern **122**, the first upper gate pad electrode **122a**, and the first upper data pad electrode **122b**. The second conductive layer **125** is patterned into the second conductive pattern **124**, the second upper gate pad

electrode **124a**, and the second upper data pad electrode **124b**. The stacked pattern of the first and second conductive patterns **122** and **124** are disposed on the passivation layer **120** and opposite to the drain electrode **108**, and electrically connected to the drain electrode **108** via the second contact hole **H2**. The stacked pattern of the first and second upper gate pad electrodes **122a** and **124a** is disposed on the passivation layer **120** and opposite to the lower gate pad electrode **102a**, and electrically connected to the lower gate pad electrode **102a** via the first contact hole **H1**. The stacked pattern of the first and second upper data pad electrodes **122b** and **124b** is disposed on the passivation layer **120** and opposite to the lower data pad electrode **106a**, and electrically connected to the lower data pad electrode **106a** via the third contact hole **H3**.

As shown in FIG. 2K, a planarization layer **129** is formed on the entire surface of the metal substrate **100** which is provided with the first and second conductive patterns **122** and **124**, the first and second upper gate pad electrodes **122a** and **124a**, and the first and second upper data pad electrodes **122b** and **124b**. The planarization layer **129** is patterned by a photolithography process using a sixth mask (not shown), thereby providing a defined planarization layer **130** with first to third contact holes **H1**~**H3** as shown in FIG. 2L. The first to third contact holes **H1**~**H3** partially expose the second upper gate pad electrode **124a**, the second conductive pattern **124**, and the second upper data pad electrode **124b**, respectively.

Then, a third metal layer **139** is formed on the entire surface of the metal substrate **100** covered with the defined planarization layer **130**, as shown in FIG. 2M. The third metal layer **130** is formed from an aluminum-neodymium alloy with superior reflectivity. The third metal layer **139** containing the aluminum-neodymium alloy is patterned into a cathode electrode **140** shown in FIG. 2N by a photolithography process using a seventh mask (not shown). The cathode electrode **140** is electrically connected to the second conductive pattern **124** via the second contact hole **H2**.

Also, a bank layer **149** is formed on the entire surface of the metal substrate partially covered with the cathode electrode **140**, as shown in FIG. 2O. The bank layer **149** is patterned into a bank pattern **150**, shown in FIG. 2P, by a photolithography process using an eighth mask (not shown). The bank pattern **150** exposes the first and third contact holes **H1** and **H3** and a part of the cathode electrode **140**. More specifically, the second upper gate pad electrode **124a** and the second upper data pad electrode **124b** are exposed by the first and third contact holes **H1** and **H3**, respectively.

Subsequently, a dry etching process is performed on the metal substrate **100** provided with the bank pattern **150**, thereby removing the second upper gate pad electrode **124a** with the first contact hole **H1** and the second upper data pad electrode **124b**, as shown in FIG. 2Q. As such, the first upper gate pad electrode **122a** formed from ITO is exposed through the first contact hole **H1**, and the first upper data pad electrode **122b** formed from ITO is exposed through the third contact hole **H3**.

Moreover, an organic light emission layer and an anode electrode are sequentially stacked on the dry-etched metal substrate **100**, even though they are not shown in the drawings. The anode electrode is formed from a transparent conductive metal.

The top emission inverted OLED device is manufactured using only 8 masks. As such, the manufacturing method of a top emission inverted OLED device according to the first embodiment can reduce the number of masks in comparison with that of the related art. In other words, the manufacturing method of a top emission inverted OLED device according to the second embodiment can reduce from a maximum of 11

masking processes in that of the related art into 8 masking processes. Therefore, the manufacturing process of the top emission inverted OLED device can be simplified, and manufacturing costs of the top emission inverted OLED device can be cut down.

FIG. 3 is a cross-sectional view showing schematically a top emission inverted OLED device according to a second embodiment of the present disclosure. The top emission inverted OLED device of the second embodiment has the same configuration as the one of the first embodiment described above, except that it includes stacked pattern of first and second cathodes **242** and **244** instead of the cathode electrode **140**, the second conductive pattern **124**, the second upper gate pad electrode **124a**, and the second upper data pad electrode **124b**. Accordingly, the description of the first embodiment to be repeated in the second embodiment of the present disclosure will be omitted. Also, the top emission inverted OLED device according to the second embodiment of the present disclosure will refer to the same reference terms and numbers for the same configuration as that according to the first embodiment.

As shown in FIG. 3, the top emission inverted OLED device according to a first embodiment of the present disclosure includes a metal substrate **100** defined into a light generation area and peripheral areas thereof. The substrate **100** includes gate and data pad portions each disposed on the peripheral areas.

At least one thin film transistor TR is formed on the light generation area of the substrate **100**. The thin film transistor TR includes a gate electrode **102** covered with a gate insulation film **110**, a semiconductor pattern **104** disposed opposite the gate electrode **102** in the center of the gate insulation film **110**, and a source electrode **106** and a drain electrode **108** arranged separately in a fixed interval from each other on the semiconductor pattern **104**.

The top emission inverted OLED device further include a conductive pattern **225** formed on a passivation (or a protective) layer **120** which covers the thin film transistor TR on the light generation area. The conductive pattern **225** is electrically connected to the drain electrode **108** of the thin film transistor TR.

The gate pad portion includes a lower gate pad electrode **102a** formed from the same metal material as the gate electrode **102**, and an upper gate pad electrode **225a** formed on the passivation layer **120**. The lower gate pad electrode **102a** is covered with the gate insulation **110**, the passivation layer **120** is formed on the gate insulation film **110**. The upper gate pad electrode **225a** is electrically connected to the lower gate pad electrode **102a**.

The data pad portion includes a lower data pad electrode **106a** formed from the same material as the source electrode **106** of the thin film transistor TR, and an upper data pad electrode **225b** formed on the passivation layer **120**. The lower data pad electrode **225b** is covered with the passivation layer **120**. The upper data pad electrode **225b** is electrically connected to the lower data pad electrode **106a**.

The top emission inverted OLED device further includes a planarization layer **230** formed on the entire surface of the substrate **100** which is provided with the conductive pattern **225**, the upper gate pad electrode **225a**, and the upper data pad electrode **225b**. Also, first and second cathode electrodes **242** and **244** are formed on the planarization layer **230** corresponding to the light generation area. The first and second cathode electrodes **242** and **244** are electrically connected to the conductive pattern **225**. Furthermore, a bank layer **250** on the substrate **100** is provided with the first and second cathode

electrodes **242** and **244**. The bank layer **250** is partially formed to expose the second cathode electrode **244**, by a pattern process.

FIG. 4A to 4P are cross-sectional views sequentially illustrating a process of manufacturing a top emission inverted OLED device of FIG. 3.

The processes of FIGS. 4A to 4H in the manufacturing method of the second embodiment are the same as those of FIGS. 2A to 2h in that of the first embodiment described above. Accordingly, the description of the first embodiment to be repeated in the second embodiment of the present disclosure will be omitted.

As shown in FIG. 4I, a conductive layer **224** is stacked on the entire surface of the metal substrate **100** covered with the passivation layer **120**. The conductive layer **224** is formed from indium-tin-oxide (ITO). The conductive layer **224** is patterned by a photolithography process using a fifth mask (not shown), so as to be defined into a conductive pattern **225**, an upper gate pad electrode **225a**, and an upper data pad electrode **225b**, as shown in FIG. 4J.

Also, a planarization layer **229** is formed on the entire surface of the metal substrate **100** provided with the conductive pattern **225**, the upper gate pad electrode **225a**, and the upper data pad electrode **225b**, as shown in FIG. 4K. The planarization layer **229** is patterned by a photolithography process using a sixth mask (not shown), thereby providing a defined planarization layer **230** with first to third contact holes H1~H3 as shown in FIG. 4L. The first to third contact holes H1~H3 partially expose the upper gate pad electrode **225a**, the conductive pattern **225**, and the upper data pad electrode **225b**, respectively.

Then, third and metal layers **241** and **243** are sequentially formed on the entire surface of the metal substrate **100** covered with the defined planarization layer **230**, as shown in FIG. 4M. The third metal layer **241** is formed from molybdenum (Mo), and the fourth metal layer **243** is formed from an aluminum-neodymium alloy with superior reflectivity. The third and metal layers **241** and **243** are patterned through a photolithography process using a seventh mask (not shown), and defined into a first cathode electrode **242** and a second cathode electrode **244** which are disposed in a stacked shape on the light generation area, shown in FIG. 4N. The first cathode electrode **242** is electrically connected to the conductive pattern **225** via the second contact hole H2. The first cathode electrode **242** is formed from molybdenum (Mo) between the planarization layer **230** and the second cathode electrode **244** prevents a problem of adhesive strength caused by a cathode electrode of AlNd which is formed directly on the planarization layer **230**. In other words, the top emission inverted OLED device of the second embodiment forces a cathode electrode to form a double metal layer of Mo and AlNd.

Subsequently, a bank layer **249** is formed on the entire surface of the metal substrate **100** partially covered with the stacked first and second cathode electrodes **242** and **244**, as shown in FIG. 4O. The bank layer **249** is patterned into a bank pattern **250**, shown in FIG. 4P, by a photolithography process using an eighth mask (not shown). The bank pattern **250** exposes the first and third contact holes H1 and H3 and a part of the second cathode electrode **244**. As such, the upper gate pad electrode **225a** and the upper data pad electrode **225b** are exposed by the first and third contact holes H1 and H3, respectively.

Furthermore, an organic light emission layer and an anode electrode are sequentially stacked on the above structured

metal substrate **100**, even though they are not shown in the drawings. The anode electrode is formed from a transparent conductive metal.

As described above, the top emission inverted OLED device is manufactured using only 8 masks. As such, the manufacturing method of a top emission inverted OLED device according the second embodiment can reduce the number of masks in comparison with that of the related art. In other words, the manufacturing method of a top emission inverted OLED device according the second embodiment can reduce from a maximum of 11 masking processes in that of the related art into 8 masking processes. Therefore, the manufacturing process of the top emission inverted OLED device can be simplified, and manufacturing costs of the top emission inverted OLED device can be cut down.

Although the present disclosure has been limitedly explained regarding only the embodiments described above, it should be understood by the ordinary skilled person in the art that the present disclosure is not limited to these embodiments, but rather that various changes or modifications thereof are possible without departing from the spirit of the present disclosure. Accordingly, the scope of the present disclosure shall be determined only by the appended claims and their equivalents.

What is claimed is:

1. A top-emission inverted organic light emitting diode display device, comprising:

first and second pad portions disposed on peripheral areas which correspond to outer sides of a light generation area on a metal substrate;

at least one thin film transistor formed on the light generation area;

a passivation layer formed to cover the thin film transistor on the metal substrate and include primary contact holes which partially expose the thin film transistor and the first and second pad portions;

a stacked pattern of first and second conductive patterns formed on the passivation layer and configured to make contact with the exposed part of the thin film transistor through one of the primary contact holes;

a planarization layer formed on the passivation layer including the first and second conductive patterns; and a cathode electrode formed on the light generation area and electrically connected to the second conductive pattern, wherein the planarization layer includes secondary contact holes corresponding to the primary contact holes,

wherein each of the first and second pad portions includes a first upper pad electrode formed from the same material as the first conductive pattern and a second upper pad electrode formed from the same material as the second conductive pattern on the first upper pad electrode, wherein the first upper pad electrodes are exposed through the secondary contact holes, and

wherein the cathode electrode is formed on the planarization layer.

2. The top-emission inverted organic light emitting diode display device of claim 1, wherein the first conductive pattern is formed from indium-tin-oxide and the second conductive pattern is formed from molybdenum.

3. The top-emission inverted organic light emitting diode display device of claim 1, wherein the cathode electrode is formed from an aluminum-neodymium alloy.

4. The top-emission inverted organic light emitting diode display device of claim 1, wherein edge surfaces of the first upper pad electrode are vertically same as edge surfaces of second upper pad electrode.

11

5. A top-emission inverted organic light emitting diode display device, comprising:

first and second pad portions disposed on peripheral areas which correspond to outer sides of a light generation area on a metal substrate;

at least one thin film transistor formed on the light generation area;

a passivation layer formed to cover the thin film transistor on the metal substrate and including primary contact holes which partially expose the thin film transistor and the first and second pad portions;

a conductive pattern formed on the passivation layer and configured to make contact with the exposed part of the thin film transistor through one of the primary contact holes;

a planarization layer formed on the passivation layer including the conductive pattern;

a first cathode electrode formed on the light generation area and electrically connected to the conductive pattern;

a second cathode electrode formed on the first cathode electrode; and

a bank layer formed on the planarization layer and formed to expose the second cathode electrode,

12

wherein the planarization layer includes secondary contact holes corresponding to the primary contact holes,

wherein each of the first and second pad portions includes an upper pad electrode formed from the same material as the conductive pattern,

wherein the upper pad electrodes are exposed through the secondary contact holes,

wherein the bank layer is formed to expose the upper pad electrode, and

wherein the conductive pattern is only formed at an area corresponding to the thin film transistor.

6. The top-emission inverted organic light emitting diode display device of claim 5, wherein the first cathode electrode is formed from molybdenum and the second cathode electrode is formed from an aluminum-neodymium alloy.

7. The top-emission inverted organic light emitting diode display device of claim 5, wherein the conductive pattern is formed from indium-tin-oxide.

8. The top-emission inverted organic light emitting diode display device of claim 5, wherein edge surfaces of the first cathode electrode are vertically same as edge surfaces of the second cathode electrode.

* * * * *

专利名称(译)	顶部发光倒置有机发光二极管显示装置，具有由与接触TFT的导电图案相同的材料形成的电极图案		
公开(公告)号	US8803172	公开(公告)日	2014-08-12
申请号	US12/639414	申请日	2009-12-16
[标]申请(专利权)人(译)	金永CHUL YOO JUHN SUK		
申请(专利权)人(译)	金永CHUL YOO JUHN SUK		
当前申请(专利权)人(译)	LG DISPLAY CO. , LTD.		
[标]发明人	KIM YONG CHUL YOO JUHN SUK		
发明人	KIM, YONG CHUL YOO, JUHN SUK		
IPC分类号	H01L27/32 H01L51/52		
CPC分类号	H01L27/3246 H01L27/3248 H01L27/3258 H01L27/3276 H01L2251/5315 H01L51/5221 H01L2227/323 H01L51/5231 H01L2251/5353		
审查员(译)	MAI , ANH		
优先权	1020090015460 2009-02-24 KR		
其他公开文献	US20100213482A1		
外部链接	Espacenet USPTO		

摘要(译)

公开了一种顶部发射倒置OLED器件。顶部发光倒置OLED器件包括：第一和第二焊盘部分，设置在外围区域上，所述外围区域对应于金属基板上的光产生区域的外侧；至少一个薄膜晶体管形成在光产生区域上；形成的钝化层覆盖金属基板上的薄膜晶体管，并包括部分暴露薄膜晶体管和第一和第二焊盘部分的接触孔；第一导电图案和第二导电图案的堆叠图案形成在钝化层上并且被配置为通过一个接触孔与薄膜晶体管的暴露部分接触；阴极电极形成在光产生区域上并电连接到第二导电图案；有机发光层设置在阴极上；阳极电极，设置在有机发光层上，由透明金属材料形成；电极图案由与第二导电图案相同的材料形成在其余的接触孔上，露出第一和第二焊盘部分。

